



Ampt Communication Unit

Installation Manual

57070025-1 D
©2024 Ampt LLC

Copyright 2024 Ampt LLC. All rights reserved. No part of this document may be reproduced, retransmitted, or copied in any form without the expressed and written permission of Ampt LLC.

This document contains information needed to install and commission an Ampt optimizer (including Smart String Technology[®] optimizers, String Stretch[®] optimizers, Ampt Mode[®] optimizers, String View[®] optimizers, V-match[®] optimizers, and Direct-to-Battery[®] optimizers) within a photovoltaic (PV) installation. The result? Energy realized[®].

All Ampt trademarks are the property of Ampt LLC. All trademarks are recognized even if they are not marked separately. Visit www.ampt.com/trademarks for a list of Ampt trademarks. Any unauthorized use of Ampt trademarks is prohibited. All other trademarks are the property of their respective owners.

U.S. and international patents apply to this product. For details visit: www.ampt.com/patents.

Disclaimer of Liability

Ampt makes no representations, expressed or implied, that with respect to this documentation or any of the equipment and/or software it may describe, including (with no limitation) any implied warranties of utility, merchantability, or fitness for any particular purpose. All such warranties are expressly disclaimed. Ampt shall not be liable for any indirect, incidental, or consequential damages under any circumstances. (The exclusion of implied warranties may not apply in all cases under some statutes, and thus the above exclusion may not apply.)

The following information is subject to change without notice, even though every attempt has been made to make this document complete, accurate and up to date. Readers are cautioned, however, that Ampt reserves the right to make changes without notice and shall not be responsible for any damages, including indirect, incidental, or consequential damages, caused by reliance on the material presented, including, but not limited to, omissions, typographical errors, arithmetical errors or listing errors in the content material.

WARNING

Any use of the Ampt String Optimizer that is not expressly authorized in this manual or associated documentation is expressly prohibited by Ampt. Ampt disclaims any responsibility or liability for such prohibited use.

General Safety

Installation and maintenance should be performed only by qualified persons. Installers and maintenance personnel assume the risk of all injury that might occur during installation or maintenance including, without limitation, the risk of electric shock. Follow your safety procedures and protocols.

All electrical installations must be done in accordance with the local and National Electrical Code ANSI/NFPA 70; Canadian Electrical Code, Part I; or the applicable standards, codes, and regulations for your region.

Failure to follow this manual will void warranty.

The Ampt product contains no user-serviceable parts. All repairs and maintenance should be handled in accordance with the instructions and terms contained in the product warranty.

The Ampt communication unit is used with Ampt optimizers. Before installing or using the Ampt optimizer, read all instructions and safety messages on the optimizer and in this manual. Follow the safety precautions for this product as well as the other components in the PV system.

Keep this manual.

Safety Message Types

The following messaging is used to identify a hazard to equipment or personnel:

 **DANGER**

Indicates a hazardous situation which, if not avoided, will result in death or serious injury.

 **WARNING**

Indicates a hazardous situation which, if not avoided, could result in death or serious injury.

 **CAUTION**

Indicates a hazardous situation which, if not avoided, could result in minor or moderate injury.

NOTICE

Indicates information considered important but not hazard, or personal injury, related - for example, property damage.

Table of Contents

Disclaimer of Liability	3
General Safety	4
Safety Message Types	4
Chapter 1: Product Overview	6
Physical Overview	7
Dimensional Drawings	8
Ampt CU	8
Ampt CU Mounting Holes and Hardware.....	9
Specifications.....	10
Modbus Register Map.....	11
Chapter 2: Installing the Ampt CU	12
Overview	12
Connecting the Antenna.....	12
Mounting Considerations	13
Ampt CU Radio Wave Ranges	13
String Optimizer Antenna Location	13
Mounting Methods	14
Pole Mounting Examples.....	14
Connecting Ethernet	15
Connecting Power over Ethernet	16
Configuring Network Settings and Establishing Communications	17
Overview of Ampt CU menu options.....	18
Appendix.....	19
Compliance.....	19
FCC Compliance.....	19
RSS-GEN	19
Avis IC.....	20
RSS-GEN	20
Ampt Support Contacts.....	20

Chapter 1: Product Overview

The Ampt Communication Unit (Ampt CU) provides wireless two-way communication with Ampt String Optimizers.

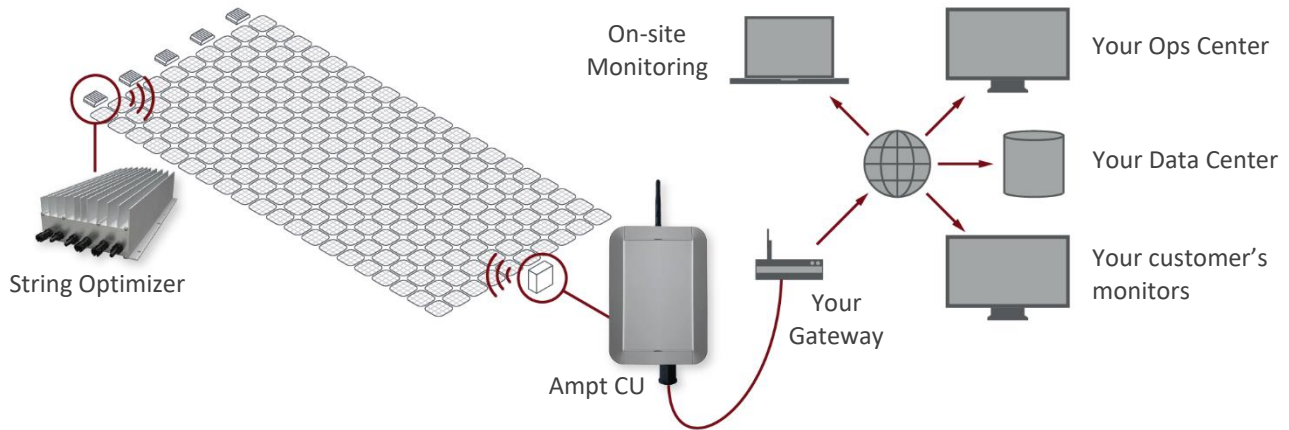

Figure 1: String-level data is transmitted from the String Optimizers to the Ampt CU and then to your SCADA system

Ampt String Optimizers are DC/DC converters that are used to lower the cost and improve the performance of new PV systems, repower existing systems to produce more energy, and enable lower cost DC-coupled storage systems. Ampt String Optimizers perform maximum power point tracking on each string while eliminating half of the electrical balance of system components and enabling lower cost per watt inverters and battery-related power components. Learn more at www.ampt.com.

The Ampt Communication Unit (Ampt CU) is paired with Ampt String Optimizers to provide string-level data for enhanced commissioning and O&M capabilities. Ampt optimizers transmit this StringView[®] optimizer data via two-way wireless communications to an Ampt CU. The Ampt CU passes records to your SCADA or data monitoring system to make the information available in the field, at your remote operations center, or through a third-party monitoring service.

Physical Overview

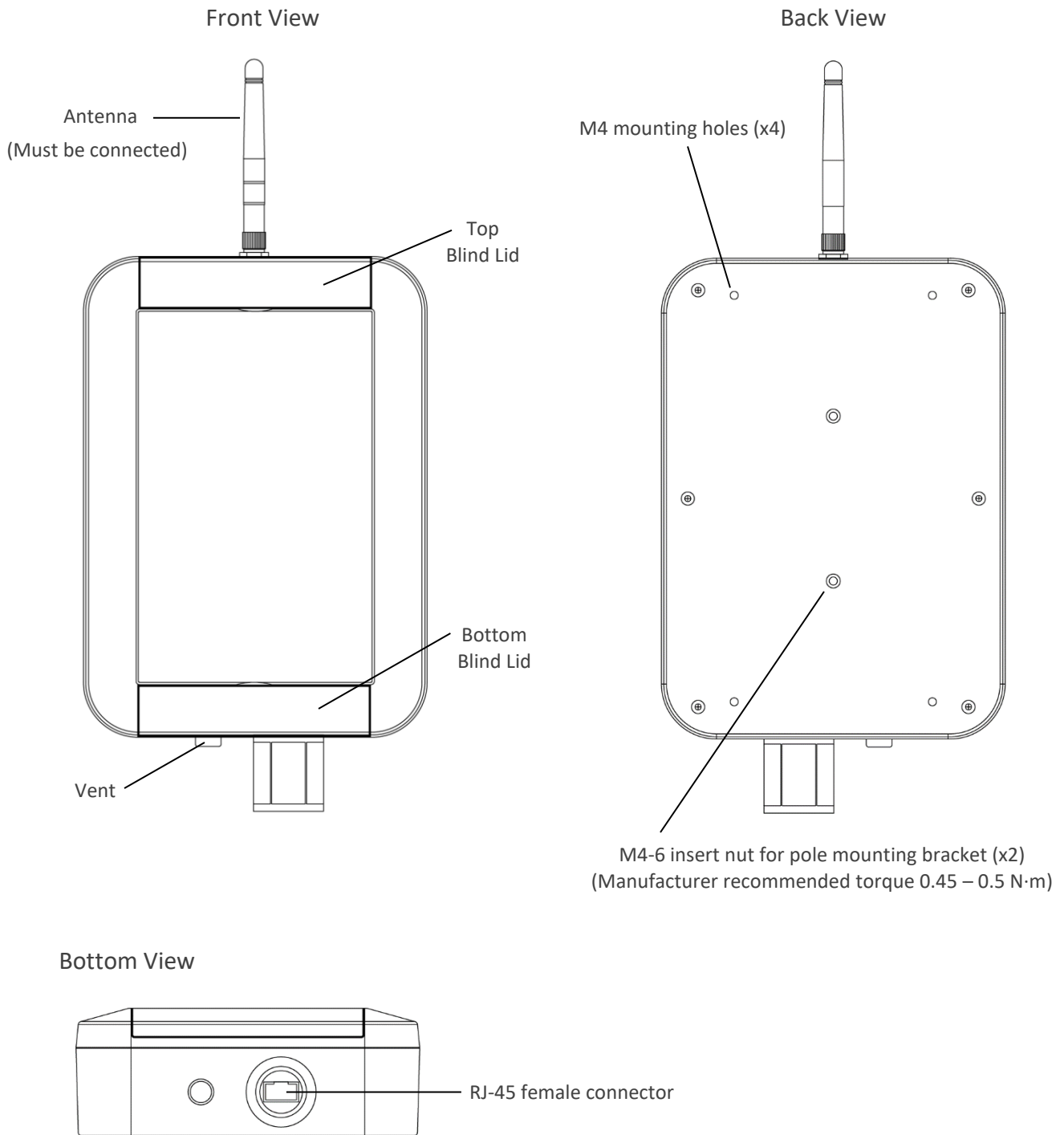

Figure 2: Ampt CU physical overview

Dimensional Drawings

Ampt CU

The dimensions for the Ampt CU are shown below.

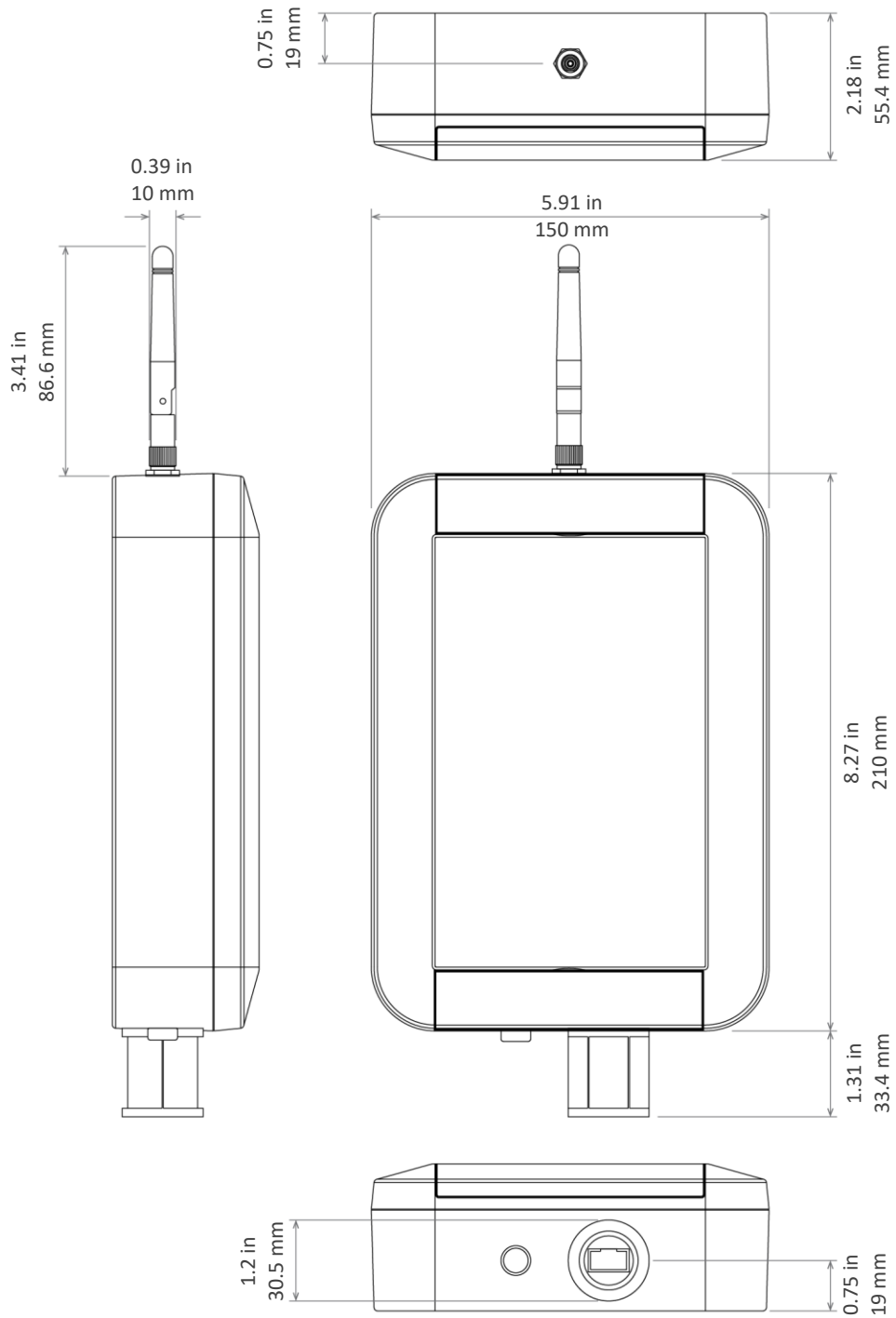

Figure 3: Ampt CU Dimensional drawings

Ampt CU Mounting Holes and Hardware

The dimensions for the Ampt CU mounting holes, pole mount bracket, and pole mount belt are shown below.

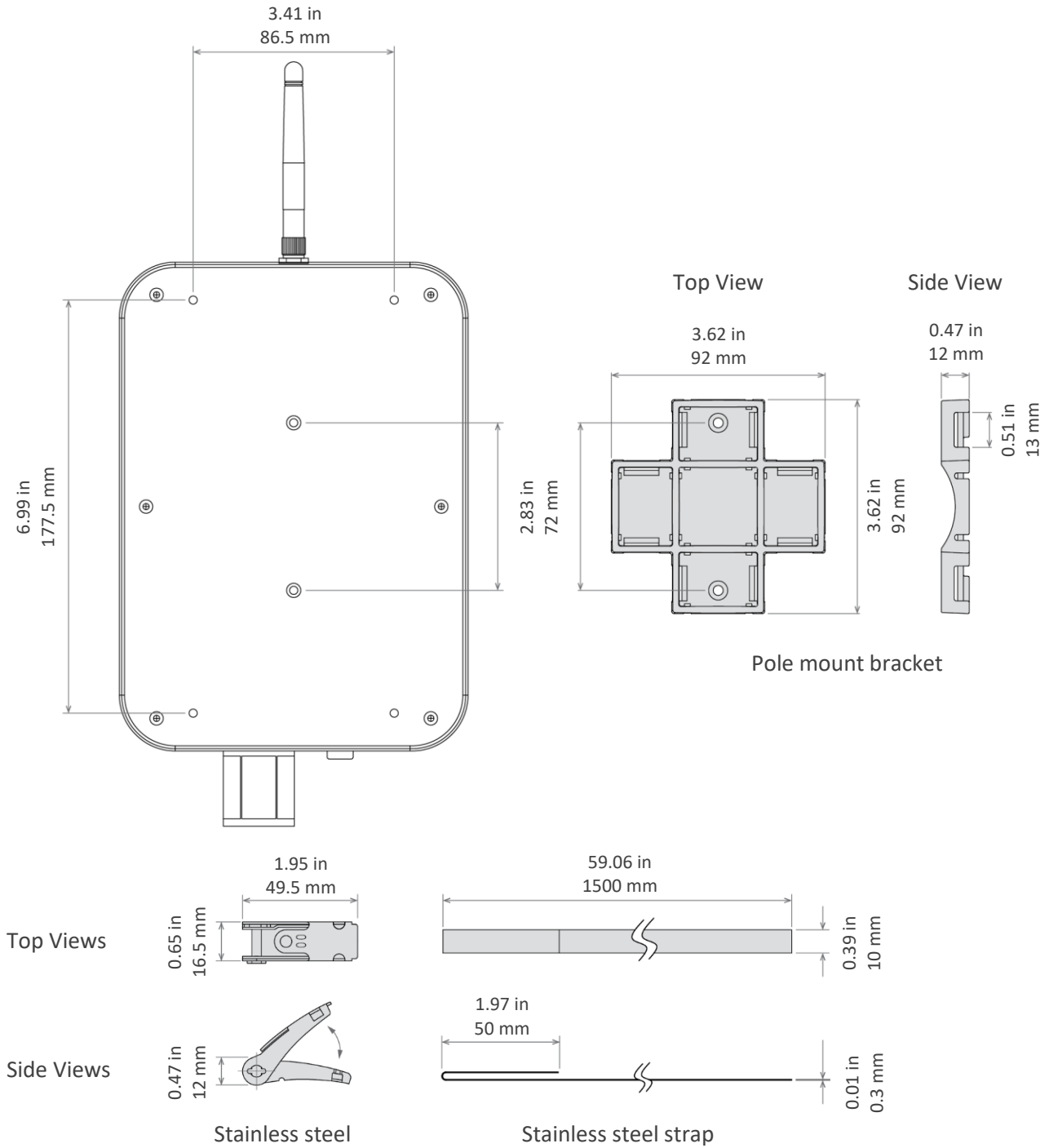

Figure 4: Dimensions for the Ampt CU mounting holes, pole mount bracket, and pole mount belt

Specifications

Data Communications	
Interface with Ampt optimizers	Two-way wireless
Number of Communication Units per MW	1 - 2
Interface with data monitoring system	Modbus TCP and HTTP JSON
Connection with data monitoring	Ethernet 10/100 Base T
Measurement accuracy	±0.25%
Data interval	1 minute
Local data storage	45 day rolling buffer
Electrical	
Power supply	Power over Ethernet (PoE) power consumption < 4.5W
Power over Ethernet (PoE)	Class 0, 802.3af Modes A and B, 802.3at Type 1 (RJ-45 connector)
Nominal operating voltage at Ampt CU	48 V
Mechanical	
Weight	1.23 lbs. 556 g
Dimensions ¹ (H x L x W)	12.99 in x 5.91 in x 2.18 in (330 mm x 150 mm x 55.4 mm)
Ingress protection	IP67
Ambient temperature operating range	-4 °F to +140 °F (-20 °C to +60 °C)
General	
Compliance	FCC Part 15, class B ETL to IEC/UL 62368-1 CSA C22.2 62368-1

1. Height dimension includes fully extended antenna. Width dimension increases by 0.47 in (12 mm) when pole mount bracket is used.

Modbus Register Map

Ampt's StringView® optimizer records use the SunSpec protocol for device ID and variable record length to enable site-specific operation.

Start offset	Size	Name	Type	R/W	Description
1	2	SID	uint32	R	A well-known value 0x53756e53, uniquely identifies this as a SunSpec Modbus Map
3	1	ID	uint16	R	A well-known value 1, uniquely identifies this as a SunSpec Common Model
4	1	L	uint16	R	Well-known # of 16-bit registers to follow: 66
5	16	Manufacturer	string	R	A well-known value registered with SunSpec for compliance: "Ampt"
21	16	Model	string	R	Manufacturer specific value "Communication Unit"
37	8	<i>Reserved</i>	-	-	
45	8	Version	string	R	Software Version
53	16	Serial Number	string	R	Manufacturer specific value
69	1	Device Address	int16	R/W	Modbus Device ID
71	1	ID	uint16	R	Ampt SunSpec Vendor Code 64050
72	1	L	uint16	R	Variable number of 16-bit registers to follow: 12 + N*16
73	1	DCA_SF	int16	R	Current scale factor
74	1	DCV_SF	int16	R	Voltage scale factor
75	1	<i>Reserved</i>	-	-	
76	1	DckWh_SF	int16	R	Energy Scale Factor
77	1	<i>Reserved</i>	-	-	
78	1	N	uint16	R	Number of strings
79	6	<i>Reserved</i>	-	-	
<i>Register blocks for string data follow. Repeat block for each string.</i>					
85	1	String ID	int16	R	String number
86	2	<i>Reserved</i>	-	-	
88	2	String data timestamp	uint32	R	UTC timestamp of the measurements
90	1	OutDCA	int16	R	String output current in mA
91	2	OutDCV	uint32	R	String output voltage in mV
93	2	In1DCV	uint32	R	String input 1 voltage in mV
95	2	In2DCV	uint32	R	String input 2 voltage in mV
97	2	DCWh	uint32	R	Daily integrated string output energy in Wh
99	1	In1DCA	int16	R	String input 1 current in mA
100	1	In2DCA	int16	R	String input 2 current in mA
<i>Repeat block for additional strings</i>					

Chapter 2: Installing the Ampt CU

Overview

This chapter explains the installation requirements, considerations, and steps that help ensure proper operation of the Ampt CU.

Connecting the Antenna

NOTICE

Use a wrench on the housing connector to prevent it from turning when connecting the antenna.

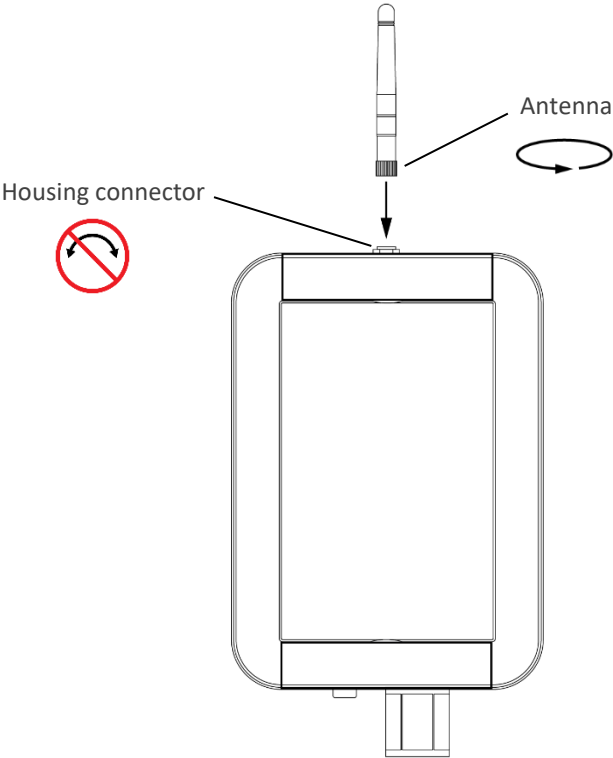

Figure 5: Do not allow the housing connector to turn when connecting the antenna.

Mounting Considerations

Ampt CU Radio Wave Ranges

The nominal communication range for the Ampt CU is 50 meters (160 feet) and up to 70 meters (230 feet) if there are no obstructions between the Ampt CU and String Optimizer. The actual ranges depend on the mounting position of the String Optimizers relative to the Ampt CU, obstructions between the String Optimizer and the Ampt CU, and other variables common with wireless communications. To maximize radio wave range, avoid mounting the Ampt CU near large metal objects like inverters, combiner boxes, tracker arms, etc.

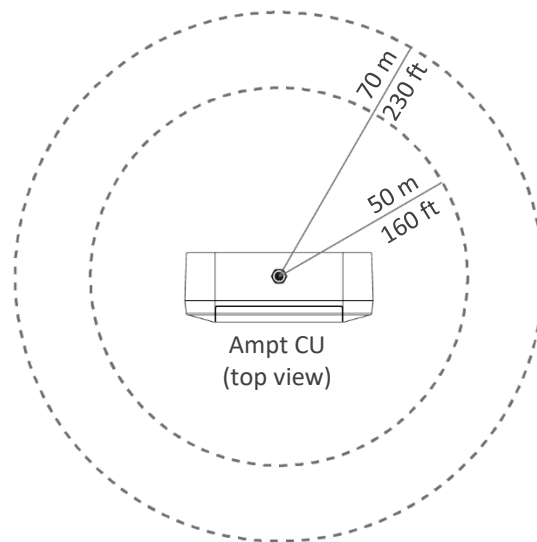

Figure 6: Top view of the Ampt CU with radio signal ranges (Ampt CU not to scale)

String Optimizer Antenna Location

Ampt String Optimizers have an antenna on the opposite side of the connectors. Keep the plastic cover clear from obstructions - including cables, mounting hardware, and PV modules, to allow radio waves from the Ampt CU.

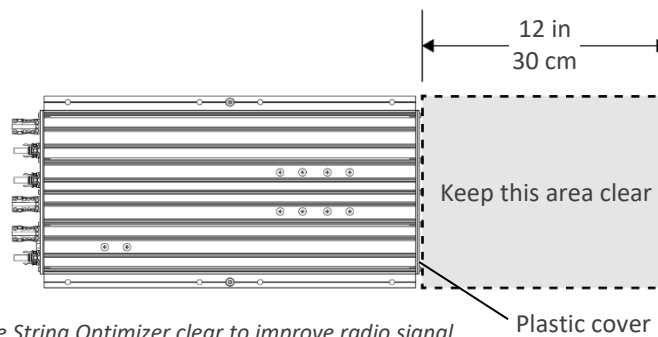

Figure 7: Keep this area of the String Optimizer clear to improve radio signal

Mounting Methods

Use the included mounting bracket and belts to mount to a pole or use the mounting holes under the top and bottom blind covers to mount the Ampt CU to a flat surface.

Pole mounting bracket

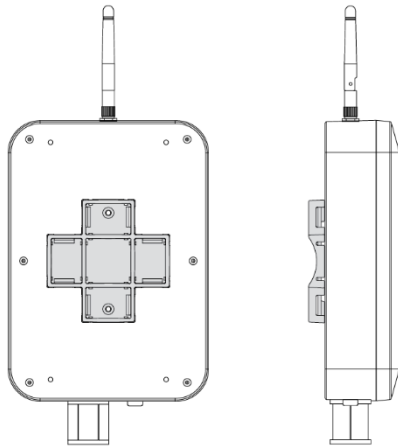

Figure 8: Mounting bracket attached to the back of the Ampt CU

Mounting holes for flat surface

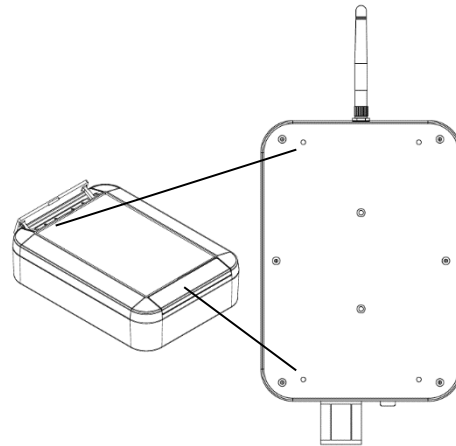

Figure 9: Mounting holes behind the blind lid on the front of the Ampt CU

Pole Mounting Examples

The mounting examples below minimize obstructions to the antenna. To maximize radio wave range, avoid mounting the Ampt CU near large metal objects like inverters, combiner boxes, tracker arms, etc.

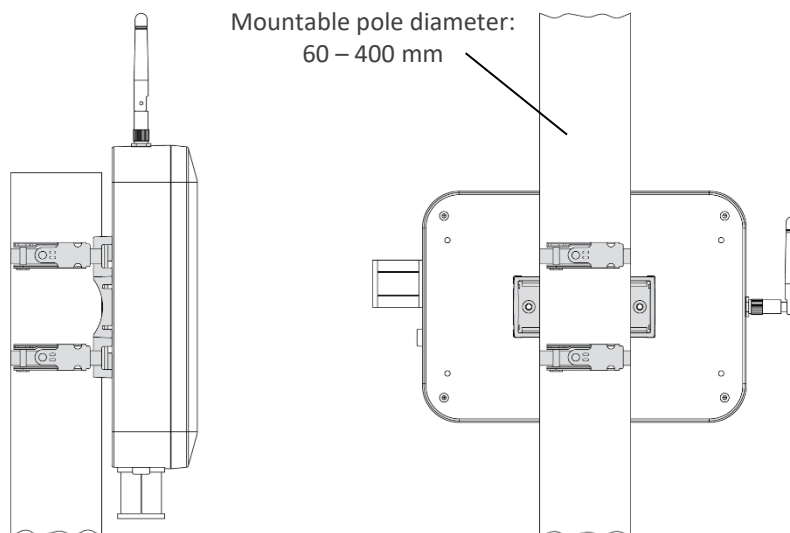

Figure 10: Mounting examples that minimize obstructions

Connecting Ethernet

Follow the diagram to connect Ethernet to the Ampt CU. The sealant, cinch nut, and fitting are included with the Ampt CU.

NOTICE

Do not allow the RJ45 receptacle housing to turn when tightening the cable fitting and cinch nut.

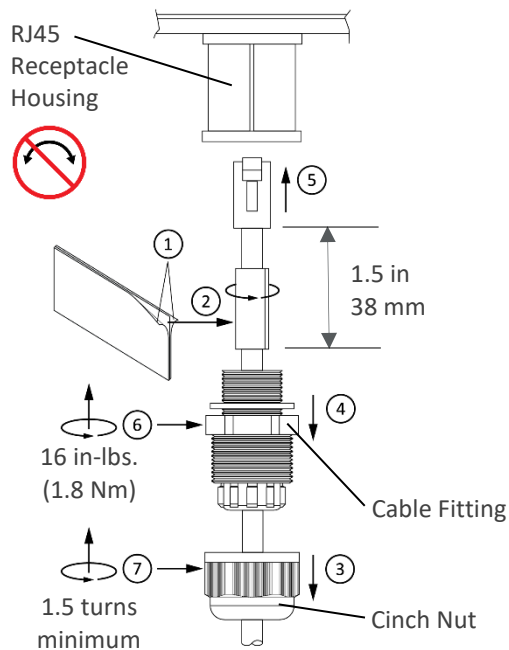

1. Remove plastic on both sides of sealant.
2. Apply the sealant as shown and mold around the cable.
3. Slide the cinch nut over the cable.
4. Slide the fitting over the cable with the orientation shown.
5. Plug the Ethernet cable into the connector.
6. Thread the cable fitting into the RJ45 receptacle housing to a torque rating of 16 inch-pounds (1.8 Newton-meters) to ensure a water-tight seal. Make sure the RJ45 receptacle housing does not move while tightening the cable fitting.
7. Thread the cinch nut onto the cable fitting using a minimum of 1.5 turns.

Figure 11: Connecting the Ethernet cable

Connecting Power over Ethernet

Use a Power over Ethernet (PoE) injector that meets the requirements in the *Specifications* section. The diagram below illustrates the basic installation of a PoE injector. Notice that the maximum length of the power + data cable should be less than 328 feet (100 meters). Be sure to follow the installation instructions that come with your PoE device.

⚠ CAUTION

- Live voltages may be present on the PoE cables.
- Do not connect or disconnect the RJ45 connector if the PoE is powered on.

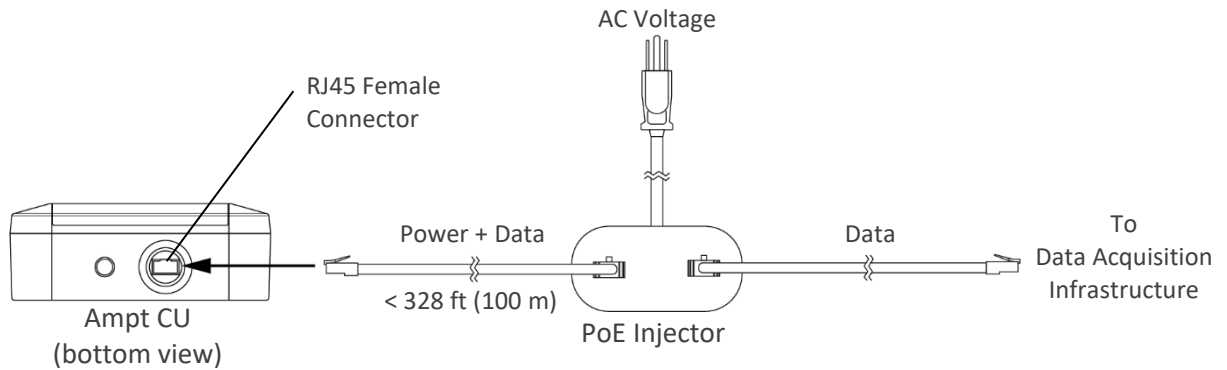

Figure 12: Generic Power over Ethernet (PoE) connection diagram – follow the instructions for your device

Configuring Network Settings and Establishing Communications

NOTICE

The tasks in this section should be performed by a Network Administrator.

Use a laptop with an ethernet connection and an internet browser to configure the Ampt CU.

Please note the following:

- The CU is configured for Static IP routing by default on the LAN
- The web interface to configure the Ampt CU is accessed via port 8080
- Modbus data is accessed via port 502

To configure the Ampt CU network settings:

1. Ensure the laptop's LAN settings are configured for a gateway setting of 10.60.80.1, netmask 24 (255.255.255.0) and a static IP of 10.60.80.90 (any IP in the range, as long as it is not .91).
2. Connect the Ampt CU to a PoE switch or injector then power on the switch or injector. This should be done before connecting through a LAN, since your LAN setting may create a conflict.
3. Open the laptop's web browser and enter `http://10.60.80.91:8080/` in the address bar. This may take several minutes after powering the PoE source.
4. Complete the fields on the login page
 - a. Login: *admin*, Password: *password*
5. Once logged in, the Ampt CU home screen is displayed. Follow the onscreen instructions to establish communications with Ampt String Optimizers.

Overview of Ampt CU menu options

After logging in to the Ampt CU, the menu provides access to various features and functionality. Follow the onscreen instructions for each option.



Figure 13: Ampt CU user menu

- Home
 - At initial startup, this page provides on-screen instructions to establish communications with the Ampt String Optimizers.
 - Once communications are established, this screen provides the string-level data being reported by the optimizers.
- Settings
 - Configure network settings
 - Set time zone and configure time
 - Reboot the system
- Modbus
 - Provides a reference for the Modbus map
- Download
 - Provides access to download data reported from Ampt String Optimizers in CSV format. A new CU will not have any data available until it has been online at least a day with Ampt String Optimizers reporting.
- admin
 - Allows access to change password and log out, once logged in

Appendix

Compliance

FCC Compliance

This device complies with part 15 of the FCC Rules. Operation is subject to the following two conditions: (1) This device may not cause harmful interference, and (2) this device must accept any interference received, including interference that may cause undesired operation.

This equipment complies with radiation exposure limits set forth for uncontrolled environment and must be installed to provide a separation distance of at least 20 cm from all persons.

IMPORTANT! Changes or modifications not expressly approved by Ampt LLC could void the user's authority to operate the equipment.

Model: 31570025
FCC ID: X3R-31570025
IC: 8399A-31570025

RSS-GEN

This device contains license-exempt transmitter(s)/receiver(s) that comply with Innovation, Science and Economic Development Canada's license-exempt RSS(s). Operation is subject to the following two conditions:

1. This device may not cause interference.
2. This device must accept any interference, including interference that may cause undesired operation of the device.

Avis IC

Cet appareil est conforme à la partie 15 des règles de la FCC. Son fonctionnement est soumis aux deux conditions suivantes: (1) Ce dispositif ne peut causer des interférences nuisibles, et (2) cet appareil doit accepter toute interférence reçue, y compris les interférences qui peuvent provoquer un fonctionnement indésirable.

Cet équipement est conforme aux limites d'exposition aux rayonnements établies pour un environnement non contrôlé et doit être installé pour fournir une distance de séparation d'au moins 20 cm de toutes les personnes.

IMPORTANT! Les changements ou modifications non expressément approuvés par Ampt LLC pourraient annuler l'autorité de l'utilisateur à utiliser l'équipement.

Model: 31570025
FCC ID: X3R-31570025
IC: 8399A-31570025

RSS-GEN

L'émetteur/récepteur exempt de licence contenu dans le présent appareil est conforme aux CNR d'Innovation, Sciences et Développement économique Canada applicables aux appareils radio exempts de licence. L'exploitation est autorisée aux deux conditions suivantes:

1. L'appareil ne doit pas produire de brouillage.
2. L'appareil doit accepter tout brouillage radioélectrique subi, même si le brouillage est susceptible d'en compromettre le fonctionnement.

Ampt Support Contacts

Global
support@ampt.com

North America
+1 970.372.6951

Europe
+49 7456 20 88 42

Japan
+81.45.565.9977

